



# Q Series 90 CRI High Bay

## Applications

The Q Series 90 CRI High Bay family is a versatile solution for endless applications. With a lightweight extruded aluminum body and included mounting hardware, the Q Series QHB by TCP is quick to install and will provide a long-lasting, durable light source for years to come.

## Features

- Lightweight, quick install construction
- Standard frosted lens for glare control
- No shadows for smooth, even lighting
- Damp location rated
- 0-10V smooth, no-flicker dimming
- Operating temperature: -4°F to 122°F
- 250W or 400W HID equivalent
- Long 50,000 hour rated life
- LED design provides wide beam spread and clean cutoff
- Optional motion sensors available
- Includes 6-foot power cord

## Hardware Included

- 2 tong hangers
- 5' jack chains
- 6' pre-wired cord

Item Number	
Notes	Type



### Listings

cULus Listed  
RoHS Compliant

### Warranty

Five year limited warranty against defects in manufacturing.

## Installation

Before hanging installation, please consult your local ordinances and building codes.

## Catalog Ordering Matrix Example: QHB2UZDA250K90

FAMILY	LENGTH	VOLTAGE <sup>1</sup>	CONTROLS	LUMEN PACKAGE (Power) <sup>1,2</sup>	CCT	CRI
<b>QHB</b> - Q Series High Bay	<b>2</b> - 2 foot	<b>U</b> - 120-277V	<b>ZD</b> - 0-10V Dimming	<b>A2</b> - 13,750L (110W) <b>A3</b> - 20,625L (165W) <b>A4</b> - 27,500L (220W)	<b>40K</b> - 4000K <b>50K</b> - 5000K	<b>90</b> - 90 CRI

<sup>1</sup> Approximate lumen output. Actual performance may vary based on CCT, options selected and end use application  
<sup>2</sup> Actual wattage may differ by +/- 10%

## Field Installed Accessories

- QHB2WGUARD1 - Wire Guard for 110W Model
- QHB2WGUARD2 - Wire Guard for 130W-220W Models
- QHB2SMOUNT1 - 110W Surface Mount Kit
- QHB2SMOUNT2 - 130W-220W Surface Mount Kit



**QHB2SMOUNT1/QHB2SMOUNT2 Surface Mount Kit**  
(Shown on QHB2UZDA250K)

## Wireline Dimensions

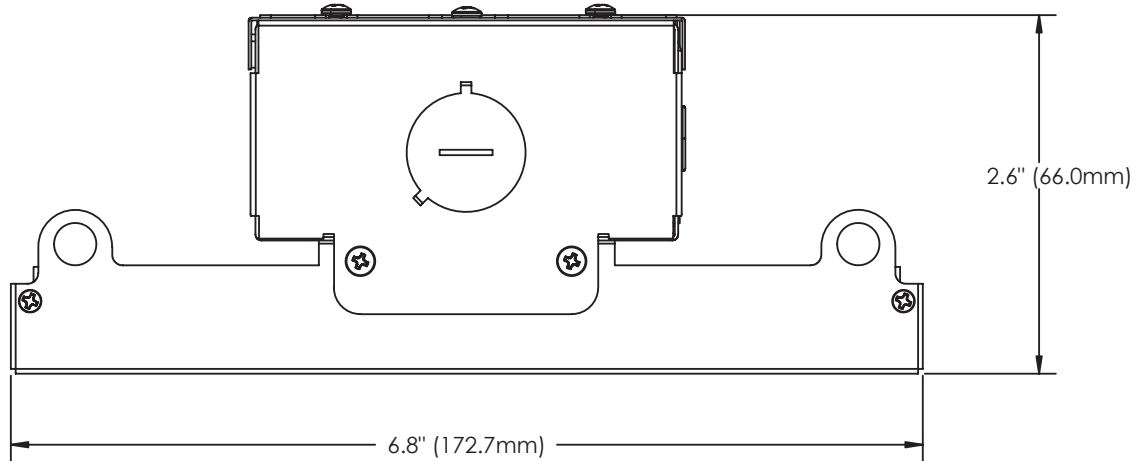
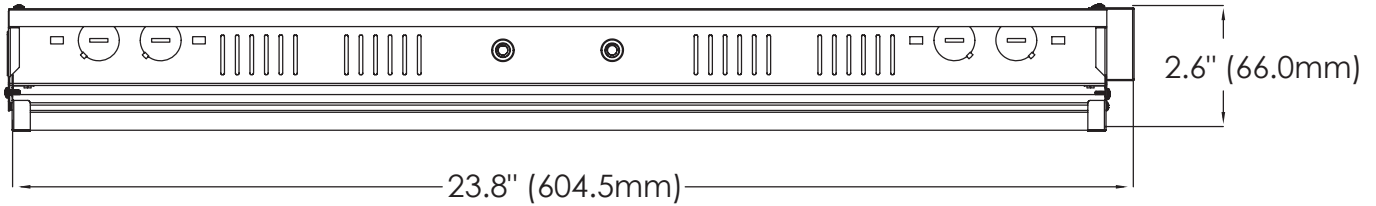

**QHB2UZDE450K (WEIGHT: 5.84lbs), QHB2UZDA350K (WEIGHT: 6.94lbs) & QHB2UZDA450K (WEIGHT: 7.61lbs)**

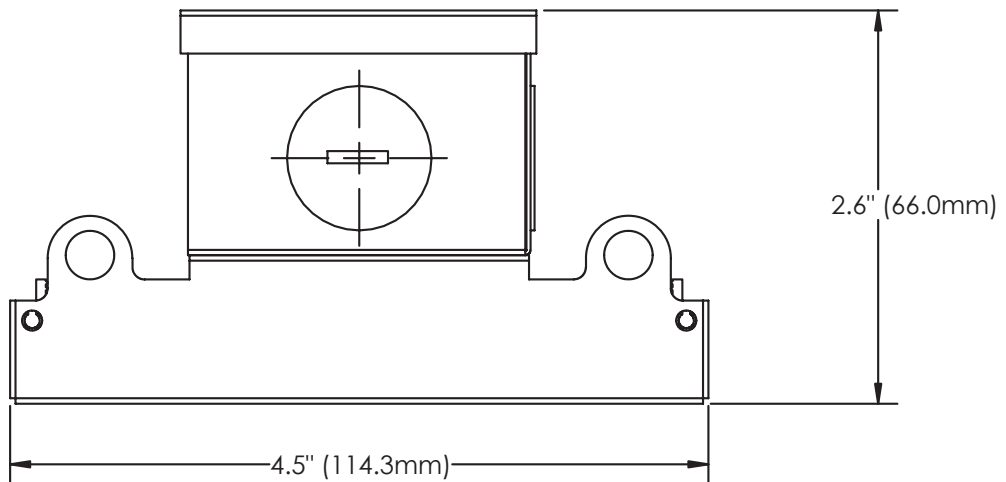

**QHB2UZDA250K (WEIGHT: 4.85lbs)**

# TECHNOLOGY CAST IN A BEAUTIFUL LIGHT

For over 30 years, TCP has been designing, developing and delivering energy-efficient lighting into the market. Thanks to our cutting-edge technology and manufacturing expertise, we have shipped billions of high quality lighting products. With TCP, you can count on a lighting product that is designed to meet the needs of the market - that transforms your surroundings and envelopes you in warmth - lighting that generates beauty with every flip of the switch.

Sales:

Date:

Model:

Project:

Rep:

Catalog Number:

Type:

Notes:



For more information on the quality and care TCP can deliver, call us at **800.324.1496** or visit [tcp.com](http://tcp.com)

325 Campus Dr. | Aurora, Ohio 44202 | P: 800.324.1496 | F: 877.487.0516